

6.

PHASE CONTROL RELAYS

6.1 THREE-PHASE MONITORS

PURPOSE

Three phase monitors serve to protect the three-phase electric motors supplied from three-phase mains, against phase collapse in at least one phase or against phase-to-phase voltage asymmetry, threatening to damage the motor.

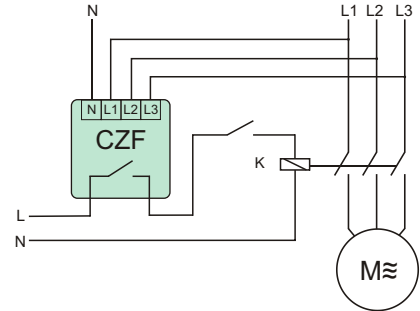

WITH FIXED ACTUATION THRESHHOLD VOLTAGE ASYMMETRY

FUNCTIONING

Phase collapse in at least one phase or voltage unbalance between phases above fixed actuation threshold causes switching-OFF the motor. The motor switching-OFF occurs with delay, which prevents any accidental motor disconnecting at temporary voltage drop. The re-connection will occur automatically at voltage increase of 5V above activation voltage (i.e. of value of voltage hysteresis). At occurrence of these disturbances, it is not possible to set a motor in motion.

CZF

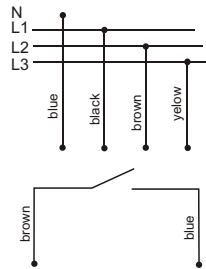

supply	3x400/230V+N
contact	1N/O
current load	<10A
sygnalling of supply	LED in each phase circuit
activation voltage asymmetry	45V ~
hysteresis	5V~
switching-OFF delay	4sec
power consumption	1,6W
connection	4x1mm ² , 2x0,75mm ² ; I=0,5m
durability	10 ⁵ of switching
working temperature	-25+40°C
dimensions	50x67x26 mm
fixing	two screws to the base

CZF-B

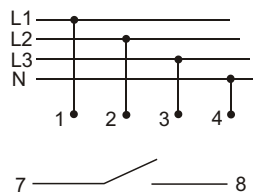

supply	3x400/230V+N
contact	1N/O
current load	<10A
sygnalling of supply	LED in each phase circuit
activation voltage asymmetry	45V ~
hysteresis	5V~
switching-OFF delay	4sec
power consumption	1,6W
connection	screw terminals 2,5mm ²
durability	10 ⁵ of switching
working temperature	-25+50°C
dimensions	2 modules (35mm)
fixing	on rail TH-35

CZF-BS

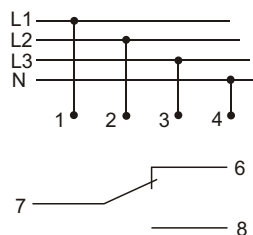

supply	3x400/230V+N
contact	1C/O
current load	<10A
sygnalling of supply	LED in each phase circuit
activation voltage asymmetry	45V ~
hysteresis	5V~
switching-OFF delay	4sec
power consumption	1,6W
connection	screw terminals 2,5mm ²
durability	10 ⁵ of switching
working temperature	-25+40°C
dimensions	2 modules (35mm)
fixing	on rail TH-35

CZF-310

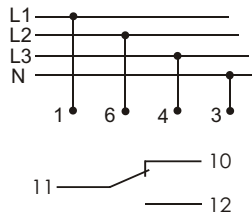

supply	3x400/230V+N
contact	1C/O
current load	<10A
sygnalling of supply	LED in each phase circuit
activation voltage asymmetry	45V~
activation voltage	185V~
histeresis	5V~
switching-OFF delay	4sec
power consumption	0,56W
connection	screw terminals 2,5mm ²
durability	10 ⁵ of switching
working temperature	-25+40°C
dimensions	1 module (18mm)
fixing	on all TH-35

AND ADJUSTABLE ACTUATION THRESHHOLD AT VOLTAGE ASYMMETRY

FUNCTIONING

Phase collapse in at least one phase or voltage unbalance between phases above set value causes switching-OFF the motor. The motor switching-OFF occurs with 4 sec delay, which prevents any accidental motor disconnecting at temporary voltage drop. The re-connection will occur automatically at voltage increase of 5V above activation voltage (i.e. of value of voltage hysteresis). At occurrence of these disturbances, it is not possible to set a motor in motion.

CZF-BR

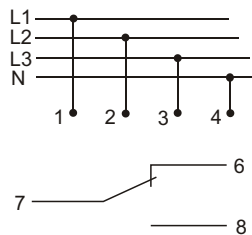

supply	3x400/230V+N
contact	1C/O
current load	<10A
sygnalling of supply	LED in each phase circuit
activation voltage asymmetry	40+80V~
histeresis	5V~
switching-OFF delay	4sec
power consumption	1,6W
connection	screw terminals 2,5mm ²
durability	10 ⁵ of switching
working temperature	-25+50°C
dimensions	2 modules (35mm)
fixing	on rail TH-35

CZF-311

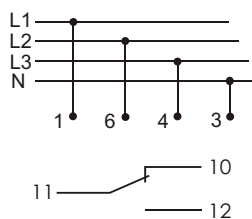

supply	3x400/230V+N
contact	1C/O
current load	<10A
sygnalling of supply	LED in each phase circuit
activation voltage asymmetry	40+80V~
activation voltage	175+190V~
histeresis	5V~
switching-OFF delay	4sec
power consumption	1,6W
connection	screw terminals 2,5mm ²
durability	10 ⁵ of switching
working temperature	-25+40°C
dimensions	1 module (18mm)
fixing	on rail TH-35

CZF-BT WITH ADJUSTABLE ACTUATION TIME 0,5÷15sek

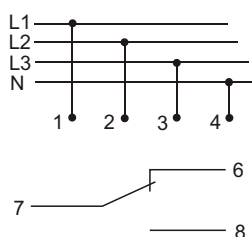

supply	3x400/230V+N
contact	1C/O
current load	<10A
sygnalling of supply	LED in each phase circuit
activation voltage asymmetry	40+80V~
histeresis	5V~
switching-OFF delay	0,5+15sec
power consumption	1,6W
connection	screw terminals 2,5mm ²
durability	10 ⁵ of switching
working temperature	-25+50°C
dimensions	2 modules (35mm)
fixing	on rail TH-35

CZF-312 MONITOR WITHOUT ACTION DELAY 0,3SEC.

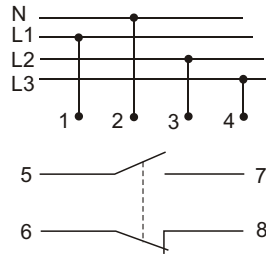

supply	3x400/230V+N
contact	1N/O, 1N/C
current load	2x(<5A)
sygnalling of supply	LED in each phase circuit
activation voltage asymmetry	40+55V~
activation voltage	175+190V~
hysteresis	5V~
switching-OFF delay	0,2sec
power consumption	1,2W
connection	screw terminals 2,5mm ²
durability	10 ⁵ of switching
working temperature	-25+40°C
dimensions	1 module (18mm)
fixing	on rail TH-35

CZF-331 WITH TWO SEPARATED CONTACTS 2C/O.

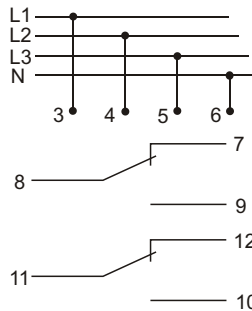

supply	3x230/400V+N
contact	2C/O
current load	2x[<8A]
sygnalling of supply	LED in each phase circuit
activation voltage asymmetry	40+80V~
hysteresis	5V~
switching-OFF delay	4sec
power consumption	1,2W
connection	screw terminals 2,5mm ²
durability	10 ⁵ of switching
working temperature	-25+40°C
dimensions	3 modules (52,5mm)
fixing	on rail TH-35

CZF-333

**WITHOUT NEUTRAL LEAD.
PREVENTS AGAINST SYMMETRICAL AND ASYMETRICAL VOLTAGE DROP.**

In case the voltage asymmetry above set value between phases causes the switching-OFF the motor. The switching-OFF the motor also occurs in case of phase-to-phase voltage drop below 320V. The motor switching-OFF occurs with 4 sec delay, which prevents any accidental motor disconnecting at temporary voltage drop. The re-connection will occur automatically at voltage increase of 5V above activation voltage (i.e. of value of voltage hysteresis). At occurrence of these disturbances, it is not possible to set a motor in motion.

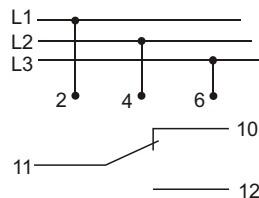

supply	3x400V
contact	1C/O
current load	<10A
sygnalling of supply	3xLED
activation voltage asymmetry	20+50V~
activation voltage	<320V~
hysteresis	5V~
switching-OFF delay	4sec
power consumption	1,6W
connection	screw terminals 2,5mm ²
durability	10 ⁵ of switching
working temperature	-25+40°C
dimensions	3 modules (52,5mm)
fixing	on rail TH-35

6.2 THREE-PHASE MONITORS WITH CHECKING STATE OF CONTACTOR CONTACTS

PURPOSE

Three phase monitor serves to protect the three-phase electric motors supplied from three-phase mains, against phase collapse in at least one phase or against phase-to-phase voltage asymmetry or against damage of contacts threatening to damage the motor.

FUNCTIONING

Phase collapse in at least one, optional phase or voltage unbalance between phase fixed actuation threshold causes switching-OFF the motor. The motor switching-OFF occurs with 4 sec delay, which prevents any accidental motor disconnecting at temporary voltage drop. The re-connection will occur automatically at voltage increase of 5V above activation voltage (i.e. of value of voltage hysteresis). At occurrence of these disturbances, it is not possible to set a motor in motion. Shining of red diode LED along with simultaneous disconnecting the apparatus permanently, indicates contactor contacts damage. Reactivation of the apparatus is possible (after contact repair), after disconnecting from supply all three phases (fuses) and then, after switching-ON anew.

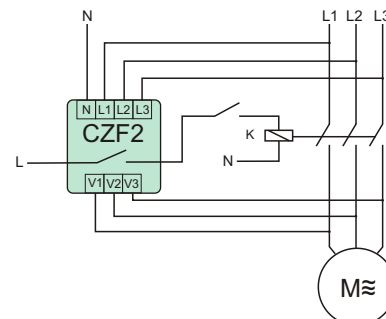

CZF2

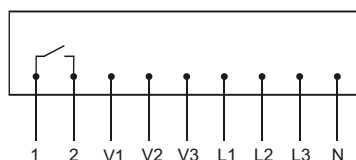

supply	3x400/230V+N
contact	1N/O
current load	<10A
sygnalling of supply	2xLED
activation voltage asymmetry	45V ~
activation voltage	185V~
hysteresis	5V~
switching-OFF delay	4sec
power consumption	1,6W
connection	screw terminals 2,5mm ²
durability	10 ⁵ of switching
working temperature	-25+40°C
dimensions	95x60x25 mm
fixing	two screws to the base

CZF2-B CONTACT CONNECTED TO POWER SUPPLY VOLTAGE.

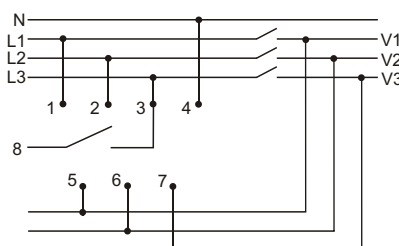

supply	3x400/230V+N
contact	1N/O
current load	<10A
sygnalling of supply	2xLED
activation voltage asymmetry	55V ~
hysteresis	5V~
switching-OFF delay	4sec
power consumption	1,6W
connection	screw terminals 2,5mm ²
durability	10 ⁵ of switching
working temperature	-25+50°C
dimensions	2 modules (35mm)
fixing	on rail TH-35

CZF2-BR CONTACT CONNECTED TO POWER SUPPLY VOLTAGE.

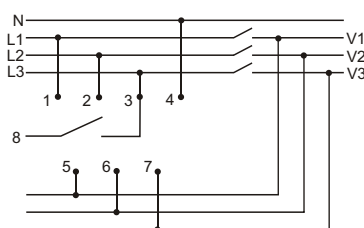

supply	3x400/230V+N
contact	1N/O
current load	<10A
sygnalling of supply	2xLED
activation voltage asymmetry	40+55V~
hysteresis	5V~
switching-OFF delay	4sec
power consumption	1,6W
connection	screw terminals 2,5mm ²
durability	10 ⁵ of switching
working temperature	-25+40°C
dimensions	2 modules (35mm)
fixing	on rail TH-35

CZF-332 WITH SEPARATED CONTACT.

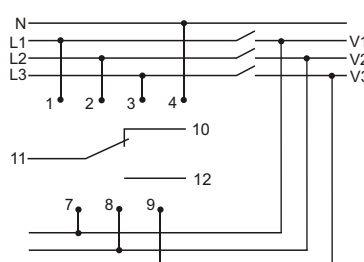

supply	3x400/230V+N
contact	1C/O
current load	<10A
sygnalling of supply	2xLED
activation voltage asymmetry	40+55V~
activation voltage	175+190V~
hysteresis	5V~
switching-OFF delay	3+5sec
power consumption	1,6W
connection	screw terminals 2,5mm ²
durability	10 ⁵ of switching
working temperature	-25+40°C
dimensions	3 modules (52,5mm)
fixing	on rail TH-35

6.3 THREE-PHASE ASYMMETRY AND SEQUENCE MONITORS

PURPOSE

Three phase and sequence monitor is designed to protect three phase electric motors against voltage drop in at least one phase or voltage asymmetry between phases, which could damage the motor, with additional protection of motor rotation direction in case of phase change before the monitor.

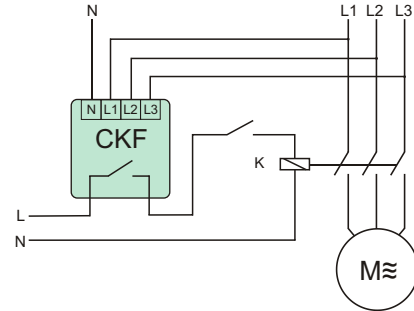

WITH FIXED ACTUATION THRESHHOLD VOLTAGE ASYMMETRY

FUNCTIONING

Voltage collapse in any phase or voltage asymmetry between phases above fixed actuation threshold causes switching-OFF the motor. The motor switching-OFF occurs after delay of 4 sec, which prevents accidental motor switching-OFF caused by instantaneous voltage drop. Switching the motor ON anew occurs automatically when the voltage increases of 5V~ above activation voltage (i.e. about value of voltage hysteresis). At occurrence of these disturbances, it is not possible to set motor in motion. In case of change of phase sequence, before the monitor, which causes change of motor rotation direction (in relation to that primarily set) is signaled by shining red diode LED along with impossibility of switching-on the motor. The re-connection is possible after the return to correct phase sequence.

CKF

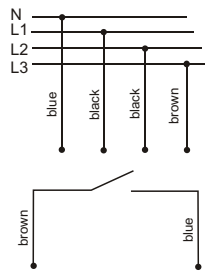

supply	3x400/230V+N
current load	<10A
signalling of supply	2xLED
activation voltage asymmetry	45V ~
hysteresis	5V~
switching-OFF delay	4sec
power consumption	1,6W
connection	4x1mm ² , 2x0,75mm ² ; l=0,5m
durability	10 ⁵ of switching
working temperature	-25+40°C
dimensions	50x67x26 mm
fixing	two screws to the base

CKF-B

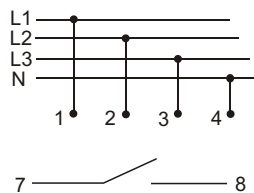

supply	3x400/230V+N
current load	<10A
signalling of supply	2xLED
activation voltage asymmetry	55V ~
hysteresis	5V~
switching-OFF delay	4sec
power consumption	1,6W
connection	screw terminals 2,5mm ²
durability	10 ⁵ of switching
working temperature	-25+50°C
dimensions	2 modules (35mm)
fixing	on rail TH-35

CKF-316

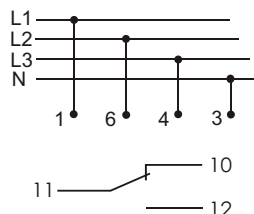

supply	3x400/230V+N
current load	<10A
signalling of supply	2xLED
activation voltage asymmetry	55V ~
hysteresis	5V~
switching-OFF delay	4sec
power consumption	1,6W
connection	screw terminals 2,5mm ²
durability	10 ⁵ of switching
working temperature	-25+40°C
dimensions	1 module (18mm)
fixing	on rail TH-35

AND ADJUSTABLE ACTUATION THRESHHOLD VOLTAGE ASYMMETRY

FUNCTIONING

Voltage collapse in any phase or voltage asymmetry between phases above set value causes switching-OFF the motor. The motor switching-OFF occurs after delay of 4 sec, which prevents accidental motor switching-OFF caused by instantaneous voltage drop. Switching the motor ON anew occurs automatically when the voltage increases about 5V~ above activation voltage. At occurrence of these disturbances, it is not possible to set a motor in motion. In case of change of phase sequence, before the monitor, which causes change of motor rotation direction (in relation to that primarily set) along with impossibility of switching-ON the motor. The rswitching-ON is possible after the return to correct phase sequence.

CKF-BR

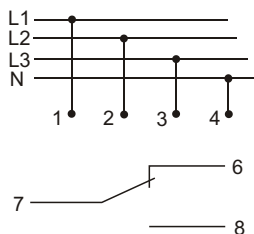

supply	3x400/230V+N
current load	<10A
contact	1 C/O
sygnalling of supplay	2xLED
activation voltage asymmetry	40+80V~
histeresis	5V~
switching-OFF delay	4sec
power consumption	1,6W
connection	terminal screws 2,5mm ²
durability	10 ⁵ of switching
working temperature	-25+50°C
dimensions	2 modules (35mm)
fixing	on rail TH-35

CKF-317

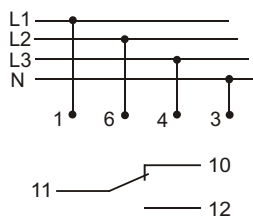

supply	3x400/230V+N
current load	<10A
contact	1 C/O
sygnalling of supplay	2xLED
activation voltage asymmetry	40+80V~
histeresis	5V~
switching-OFF delay	4sec
power consumption	0,56W
connection	terminal screws 2,5mm ²
durability	10 ⁵ of switching
working temperature	-25+40°C
dimensions	1 module (18mm)
fixing	on rail TH-35

CKF-BT

WITH ADJUSTABLE ACTUATION TIME 0,5÷15sek

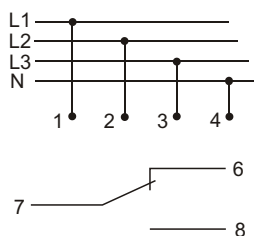

supply	3x400/230V+N
contact	1C/O
current load	<10A
sygnalling of supplay	LED in each phase circuit
activation voltage asymmetry	40+80V~
histeresis	5V~
switching-OFF delay	0,5+15sec
power consumption	1,6W
connection	screw terminals 2,5mm ²
durability	10 ⁵ of switching
working temperature	-25+50°C
dimensions	2 modules (35mm)
fixing	on rail TH-35

CKF-337

WITHOUT NEUTRAL LEAD.
PREVENTS AGAINST SYMMETRICAL AND ASYMETRICAL VOLTAGE DROP.

In case of voltage asymmetry above set value between phases causes the switching-OFF the motor. The switching-OFF the motor also occurs in case of phase-to-phase voltage drop below 320V. The motor switching-OFF occurs with 4 sec delay, which prevents any accidental motor disconnecting at temporary voltage drop. The re-connection will occur automatically at voltage increase of 5V above activation voltage (i.e. of value of voltage hysteresis). At occurrence of these disturbances, it is not possible to put a motor to motion.

Change of phase sequence, before the monitor, which causes change of motor rotation direction (in relation to that primarily set) along with impossibility of switching-ON the motor.

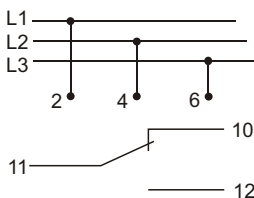

supply	3x400V
contact	1 C/O
current load	<10A
sygnalling of supplay	4xLED
activation voltage asymmetry	20+50V~
activation voltage	<320V~
histeresis	5V~
switching-OFF delay	4sec
power consumption	1,6W
connection	terminal screws 2,5mm ²
durability	10 ⁵ of switching
working temperature	-25+40°C
dimensions	3 modules (52,5mm)
fixing	on rail TH-35